

THE NEW GENERATION OF CRACK HEALER/SEALERS

BY DAVE FLAX

As long as humans have been making concrete, there has been cracking and there have been two choices: avoid the cracks to begin with or fix them later. Right about now, I can almost hear someone laughing and saying: “Yeah. Right. I can avoid cracks in my concrete?” The answer is: “In most cases, yes you can.” Today, we have a plethora of ways to help avoid annoying cracks, or at the very least, keep them very small so that they are much less of a problem. We can do things such as use low- or zero-shrinkage concrete incorporating shrinkage-reducing or shrinkage-compensating admixtures, use concrete with lower water-cement ratios (w/c) incorporating water reducers or high-range water-reducing admixtures, do a better job of curing the concrete properly, add macro- and/or microfibers to the concrete, use evaporation retarders, and perform saw-cutting operations as soon as possible with early-entry saws.

But I digress. We run into concrete cracking issues all too often. Traditionally, there have been three ways to treat cracks that are typically in the 0.01 to 0.06 in. (10 to 60 mils) width range. One way is to use waterproofing coatings that are usually acrylic-based. If properly applied, these coatings will seal the concrete but do not penetrate into the cracks to heal them or the concrete. They have the

disadvantage of being “on” the surface, which means that any physical abuse will wear them “off” the surface. Coatings obviously do no good once they wear off.

Another common method of treating concrete cracks is to use impregnating water repellants. They are usually silane, siloxane, or a silane/siloxane blend. They penetrate into the crack and coat the sides of the crack to provide a water-repellent barrier, but they do not heal the concrete.

Finally, there are healer/sealers, which have typically been methyl methacrylate, high-molecular-weight methacrylate, urethane, or epoxy. When properly formulated and used, these have the advantage of filling the cracks to provide both sealing and healing of the concrete. Furthermore, because they penetrate, they do not wear off the concrete surface.

Healer/sealers have been around for decades, but their ability to fully fill, seal, and heal cracks often yielded mixed results. When healer/sealers were first developed, it was easy to look at the viscosity of the resin as the culprit for these mixed outcomes. If the viscosity was too low, it would flow into the crack and right out the bottom of the slab/member. If the viscosity was too high, it didn’t penetrate far enough to fill the crack. However, the viscosity of the resin wasn’t the only culprit.

When it came time to develop a new generation of healer/sealers, the biggest challenge was to formulate one that filled the cracks and kept them filled. Research showed fairly quickly that it wasn’t all about the material viscosity. Other factors, which will be covered in this article, also had to be considered, including the method used to achieve the desired viscosity, modulus of elasticity, dynamic surface tension, and safety of handling.

VISCOSITY

The optimum mixed viscosity was determined to be ultra-low viscosity in the 80 to 120 cps (80 to 120 mPa-s) range. However, it was also discovered that the means used to achieve the viscosity were just as important as the viscosity itself. That’s where molecular weight distribution comes into play. This distribution allows the viscosity to be modified while maintaining the physical properties of the healer/sealer. Figure 1 shows the “narrow band width” of the molecular weight distribution, which allows the healer/sealers to have the desired vis-

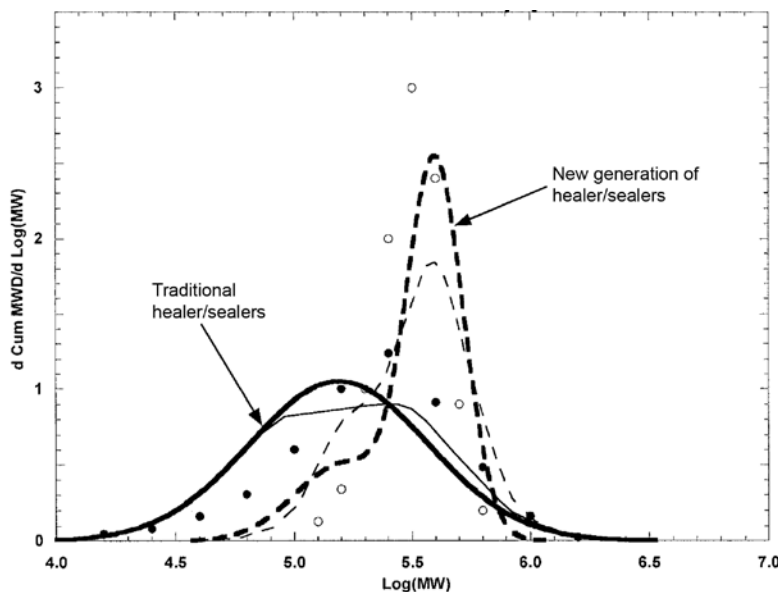

Fig. 1: Molecular weight distribution. Note the “narrow band width” of the new generation of healer/sealers versus traditional healer/sealers

cosity. The best way to visualize this is to picture a funnel with a large opening. If we put just one size aggregate in it, it will flow through readily, but if we put in a full gradation of aggregate, it will clog up and not flow (Fig. 2). This is the difference between a narrow and a wide band width.

MODULUS OF ELASTICITY

It was determined that a low modulus of elasticity was necessary in the formulation of a healer/sealer resin. The benefits of this cannot be disputed. A low-modulus resin will perform much better, where the likelihood of mechanical and/or thermal movement takes place. Because a majority of treated cracks are on bridge and parking decks, a

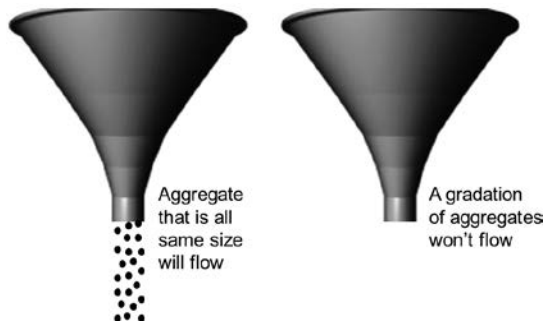

Fig. 2: Molecular weight distribution. The “narrow band width” flows better because it is all of a similar size and not a gradation

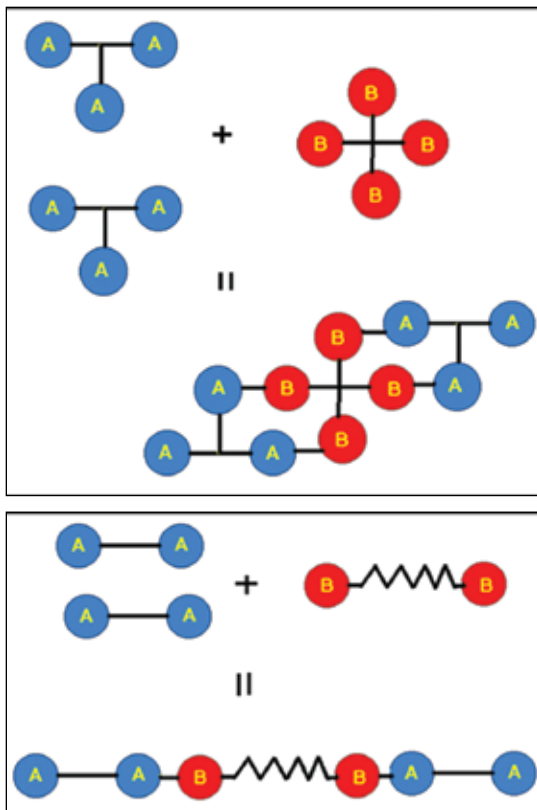

Fig. 3: Modulus of elasticity. Achieved by adjusting the cross-link density

low modulus of elasticity resin is optimal. This type of resin will seal and heal the crack, bind the crack back together, and yet allow a certain amount of movement so as to prevent re-cracking.

The desired low modulus of elasticity can be achieved by adjusting the cross-link density and the polymer flexibility (Fig. 3). In this figure, look at the upper schematic and visualize each of the straight lines as 8 ft (2.5 m) long, 2 x 4 in. (50 x 100 mm) pieces of wood. It would be very rigid and unyielding. Now, look at the lower schematic. The straight lines are still 8 ft (2.5 m) long, 2 x 4 in. (50 x 100 mm) pieces of wood but the jagged line is a thin 8 ft (2.5 m) long polyvinyl chloride (PVC) pipe. This would be very flexible. This flexibility is what makes the modulus of elasticity of the hardened healer/sealer low.

DYNAMIC SURFACE TENSION

Low surface tension is an important factor in allowing the healer/sealer to penetrate. If you don't think that surface tension can prevent penetration, look at the upper photo in Fig. 4. This is an example

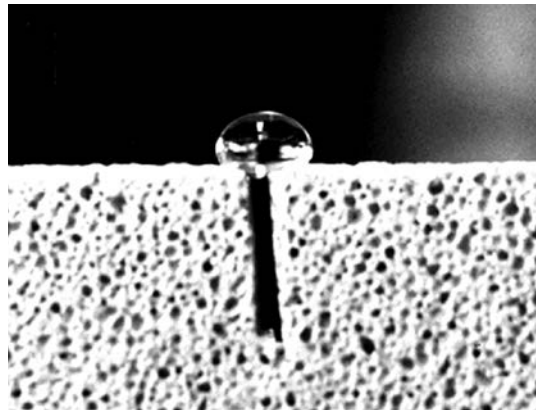
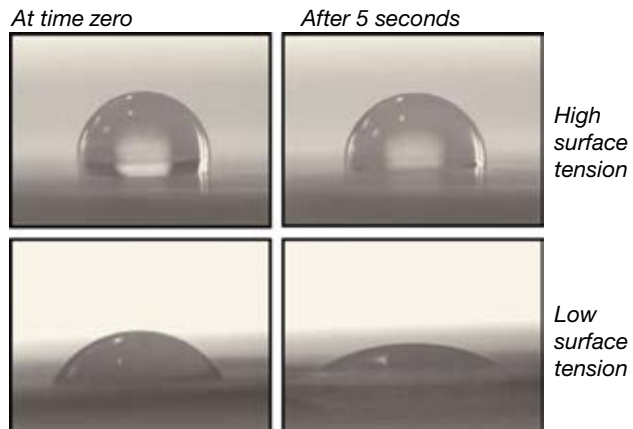

Photo of water drop on a saw cut shows the importance of surface tension. Too much surface tension and the water just won't penetrate



Photos of water drops show the effect of high and low surface tension after just five seconds

Fig. 4: Surface tension

of a resin that has high surface tension. The new generation of healer/sealers was formulated using specially designed surface tension reducing agents to reduce surface tension, which allows the healer/sealer resin to penetrate into the cracks more readily. Figure 4 also has four lower photos that show the difference between high and low surface tension and the dramatic difference in water drop spread after just 5 seconds.

SAFETY OF HANDLING

In the past, some healer/sealers have been dangerous to handle and use. Some were explosive; others had fumes that could cause serious health issues. The new generation of healer/sealers is easy to use and safe to handle.

Material Type	Range of Crack Length Filled (%)
Methyl Methacrylate	20-90
Methyl Methacrylate	1-25
Urethane	20-90
Epoxy	70-98
Epoxy	30-90
Epoxy	5-80
High Molecular Weight Methacrylate	5-40
High Molecular Weight Methacrylate	5-50
High Molecular Weight Methacrylate	5-30
High Molecular Weight Methacrylate	5-70
High Molecular Weight Methacrylate	0-80

New generation healer/sealer →

Fig. 5: Oregon DOT State Research Report SRS 500-230, dated June 2010 and titled "Crack Sealer Fill Characteristics":

- "A minimum of 70% crack fill was needed to prevent water leakage"
- "Only one of the eleven crack sealers tested consistently met the 70% threshold"

TESTING BY OREGON DOT

The Oregon Department of Transportation (DOT) did extensive testing of the new generation of healer/sealers and the most popular, commonly used healer/sealers on the market. They published their State Research Report SRS 500-230, titled "Crack Sealer Fill Characteristics," in June 2010. They concluded that: 1) "A minimum of 70% crack fill was needed to prevent water leakage"; and 2) "Only one of the eleven crack sealers tested consistently met the 70% threshold." This was the new generation of healer/sealers that this article has been describing. The results of their testing are shown in Fig. 5.

ENGINEERING PROPERTIES OF HARDENED CONCRETE TREATED WITH NEW GENERATION HEALER/SEALERS

It heals:

- Abrasion resistance (ASTM C779/C779M)—7 days old for 60 minutes: 90.2% improvement. This means that the abrasion resistance increased by a factor of 10 and in the time it would take for just 0.01 in. (10 mils) to wear away from the healed/sealed concrete surface, there would have been 0.10 in. (100 mils) worn away from untreated concrete. It truly is a healer.

It seals:

- Absorption (ASTM C413)—7 days: 89.7% improvement. This means that the absorption was only one-tenth that of the untreated concrete. It truly is a sealer.
- Acid-soluble chloride (AASHTO T 259/T 260)—90 days: 100% improvement. That means that the penetration of acid-soluble chlorides went to zero. It truly is a sealer.

Other engineering properties:

- Slant shear (ASTM C882/C882M)—14 days: 2054 psi (14.2 MPa) with the break in the concrete.
- Tensile strength (ASTM D638)—7 days: 815 psi (5.6 MPa).
- Tensile elongation (ASTM D638)—7 days: 60.6%.

HEALER/SEALER APPLICATION

The application steps after proper surface preparation are shown in Fig. 6. Steps include pre-treating large cracks if necessary; flooding coating with the ultra-low-viscosity, low-modulus epoxy; distributing the epoxy onto the substrate; removing excess epoxy; broadcasting fine sand onto the wet epoxy; removing the excess sand when resin has cured; and opening to traffic.

CONCLUSIONS

As shown in the Oregon DOT report, the new generation of healer/sealers gives superior results when compared to other available technologies. Additionally, they are both easier and safer to use.



Dave Flax is Manager of the National Business Development Group for the Southwest Region of The Euclid Chemical Company in Cleveland, OH. He received his civil engineering degree from Rensselaer Polytechnic Institute (RPI) in 1969 and has been

involved with construction and concrete since that time. He has been a field engineer, contractor, specifier, and researcher with the U.S. Army Corps of Engineers. He earned his CDT (Certified Document Technologist) and CCPR (Certified Construction Products Representative) certifications from the Construction Specification Institute (CSI). He speaks regularly to national organizations including SEA, ACI, ICRI, and CSI, both live and via webinar, has spoken at World of Concrete, and has published dozens of articles. Flax is a member of ICRI Committees 110, Guide Specifications, and 320, Concrete Repair Materials and Methods, and is a founding member of the ICRI Arizona Chapter. He was awarded the Extra Yard Award by SCCP for his 30+ years of service to the concrete industry.

Pre-treat larger cracks if necessary



Flood surface with properly mixed epoxy



Use rollers or squeegees to distribute resin material



Remove excess epoxy and immediately apply fine sand into the wet epoxy



When cured, remove excess sand and open to traffic



Fig. 6: Typical application at the Grand Ronde River Bridge in Oregon