



American Concrete Institute®
Advancing concrete knowledge

ACI RAP Bulletin 5

FIELD GUIDE TO
CONCRETE REPAIR
APPLICATION PROCEDURES

Surface Repair Using Form-and- Pump Techniques

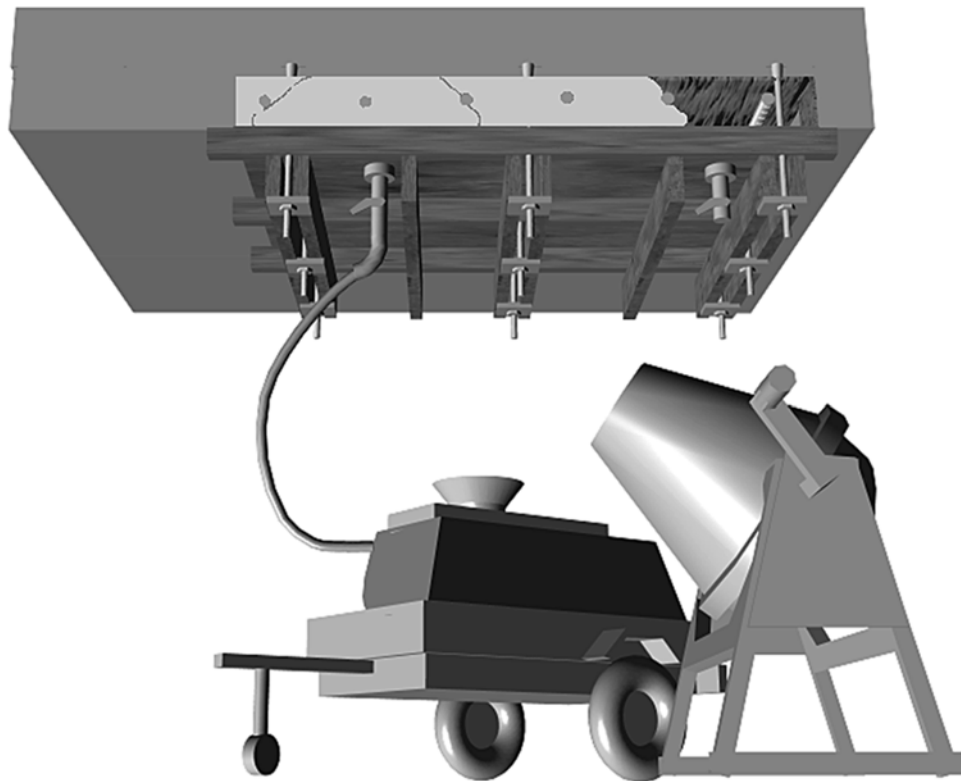

Field Guide to Concrete Repair Application Procedures

Surface Repair Using Form-and-Pump Techniques

Reported by ACI Committee E706

Brian F. Keane
Chair

J. Christopher Ball
Floyd E. Dimmick, Sr.
Peter H. Emmons*
Timothy R. W. Gillespie

H. Peter Golter
Bob Joyce
Kenneth M. Lozen

John S. Lund
Richard Montani
Jay H. Paul

George I. Taylor
Patrick M. Watson
David W. Whitmore

*Primary author.

It is the responsibility of the user of this document to establish health and safety practices appropriate to the specific circumstances involved with its use. ACI does not make any representations with regard to health and safety issues and the use of this document. The user must determine the applicability of all regulatory limitations before applying the document and must comply with all applicable laws and regulations, including but not limited to, United States Occupational Safety and Health Administration (OSHA) health and safety standards.

Structural Disclaimer

This document is intended as a voluntary field guide for the Owner, design professional, and concrete repair contractor. It is not intended to relieve the user of this guide of responsibility for a proper condition assessment and structural evaluation of existing conditions, and for the specification of concrete repair methods, materials, or practices by an experienced engineer/designer.

ACI Repair Application Procedure 5.

Copyright © 2003, American Concrete Institute.

All rights reserved including rights of reproduction and use in any form or by any means, including the making of copies by any photo process, or by electronic or mechanical device, printed, written, or oral, or recording for sound or visual reproduction or for use in any knowledge retrieval system or device, unless permission in writing is obtained from the copyright proprietors. Printed in the United States of America.

The Institute is not responsible for the statements or opinions in its publications. Institute publications are not able nor intended to supplant individual training, responsibility or judgment of the user, or the supplier of the information provided.

Introduction

The form-and-pump repair technique is a multi-step process of preparing and constructing formwork, and pumping repair material into the cavity confined by formwork and existing concrete. The form-and-pump technique allows the use of many different repair materials. The necessary requirement for material selection is pumpability. Various pumps are used, depending on the mixture design with focus on aggregate size. Prior to construction of formwork, any surfaces that may cause air to become trapped during the pumping process must be trimmed, or vent tubes installed.

Repair materials are mixed and pumped into the confined cavity. The sequence of pumping is from low points to high points and when performed overhead, from one extremity to the other. Large areas may require bulkheading to separate placements into manageable areas. When the cavity is full, pump pressure is exerted on the form, causing the repair material to consolidate and make intimate contact, and effect bonding with existing concrete surfaces. The form-and-pump technique offers many advantages to alternative techniques, such as shotcrete, hand placement, and preplaced aggregate.

Advantages include:

- Placement is not limited by thickness of repair or by size or density of exposed reinforcement;
- Repair materials are premixed and placed to provide a uniform cross section without segregation or intermediate bond lines;
- Sagging or dropouts of freshly placed materials aren't problems; all materials are supported by formwork during the placement and curing process;
- The pressurization process consolidates the repair material, providing for full encapsulation of exposed reinforcing steel;
- The formwork protects the repair material during the curing process;
- The process is less subject to individual operator error; and
- Quality assurance of the in-place repair is easier to provide.

What is the purpose of this repair?

The primary purpose for this type of repair is to restore the structural integrity, concrete cover requirements, or both, for the damaged element.

When do I use this technique?

This technique is commonly used on vertical surfaces such as walls, columns, and other combinations such as beam sides and bottoms. Separate bonding agents such as grouts or epoxy are not commonly used with this technique. It is highly recommended that for each project, a trial installation be performed to verify the preparation, material, and placement technique using quality-control procedures outlined at the end of this document.

How do I prepare the surface?

Regardless of the repair method, surface preparation is essentially the same. Concrete is removed until good quality concrete is located. Exposed bars are undercut, and surfaces

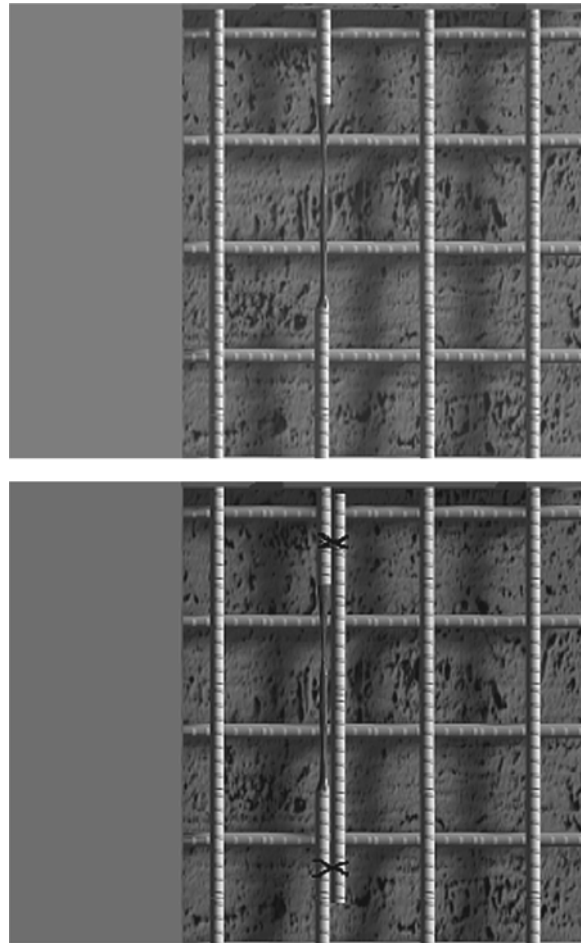

Fig. 1—Lapping of supplemental reinforcement.

are cleaned with high-pressure water or are abrasively blasted. With form-and-pump techniques, it is important to understand how the existing surfaces will permit the repair material to penetrate and flow. Surfaces that might trap air need to be trimmed, or vent pipes may be provided in the formwork. Profile roughness from hand-chipping or hydrodemolition is not generally a problem for entrapping air. Flow of the repair material (while flowing within the formed cavity) will most likely remove air from the profile.

Steps in surface preparation include the following:

Step 1—Sounding or other appropriate nondestructive concrete testing to locate areas of delamination.

Step 2—Marking of the perimeter of the repair area. Layout should be simple square or rectangular shapes. There should be no acute angles between boundary lines defining the repair area.

Step 3—Sawcutting perimeter of the repair. Note: sawcut should not be deeper than the cover over the reinforcement.

Step 4—Removal of concrete with a 15-lb chipping hammer. Hammers larger than a 15-lb class may cause damage to substrate and reinforcement.

Step 5—Reinforcement repair. When reinforcing steel is heavily corroded and the diameter is reduced, consult a structural engineer for repair procedures. For many applications, supplemental reinforcement can be lapped to adjacent damaged bars, as shown (see Fig. 1).

Step 6—Cleaning of reinforcing steel and concrete with abrasive blasting.

How do I select the proper repair material?

Constructibility requirements for materials used with the form-and-pump technique are limited only by their ability to be pumped and their flow characteristics. More important than constructibility are the materials' in-place properties, such as low drying shrinkage, compatible strength, thermal and elastic properties, and durability requirements. While constructibility of the repair materials requires good pumpability and flowability, these required characteristics should not sacrifice the requirement of low drying shrinkage. Drying shrinkage can cause cracking, delamination, inability to carry loads, and reduced durability. Pumpability and flowability can be brought to the material with aggregate shape and chemical admixtures that preserve low water-cement ratio, yet provide a pumpable mixture. Prepackaged repair materials, which are designed for pumping and incorporate shrinkage-compensating additives, are appropriate for many applications. Materials should be reviewed for effects on drying shrinkage to find those with low shrinkage.

Shrinkage testing in accordance with ASTM C 157 (modified in accordance with ASTM C 928 and measured over a 120-day period) will provide meaningful and comparable shrinkage properties.

What equipment do I need?

Pumping equipment—Pumping equipment is generally matched to the type of repair material and the size of the repair project. The specified repair material requires pumping through a pump line to the formed cavity. Cementitious repair materials have various aggregate contents and aggregate sizes. Fine-grained repair mixtures with very fine aggregate and little or no coarse aggregate can be pumped with mono-type pumps or piston/ball valve pumps.

Repair materials with large aggregates (larger than 3/8 in. [10 mm]) are best pumped with hydraulic/swing valve

STEP 3

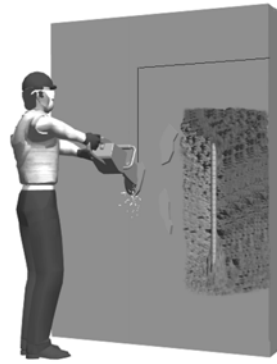

Sawcutting perimeter of repair. Note: sawcut should not be deeper than cover over reinforcement.

STEP 4



Unsound concrete removed with 15-lb chipping hammer. Hammers larger than a 15-lb class may cause damage to substrate and reinforcement.

STEP 5: Reinforcement repair: When reinforcing steel is heavily corroded and the diameter is reduced, consult a structural engineer for repair procedures. For many applications supplemental reinforcement can be lapped to adjacent damaged bars, as shown.

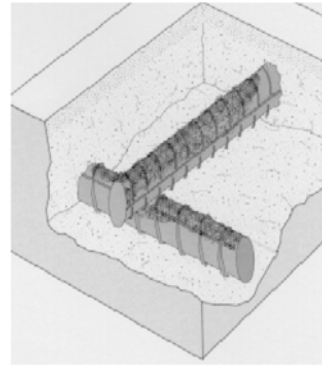

Important Note: If corroded reinforcing bars are encountered in the preparation process, then concrete surrounding the bars must be removed to fully expose the full circumference. Clearance under the bar should not be less than 3/4 in. (19 mm), or 1/4 in. (6 mm) greater than the largest aggregate size of the repair mixture, whichever is greater.

STEP 6

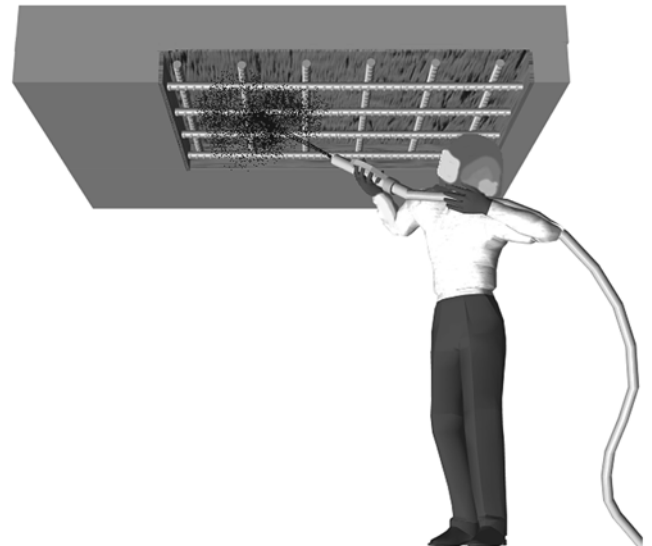

Cleaning of reinforcing steel and concrete with abrasive blast.

STEP 1



Sounding of concrete to locate areas of delamination.

STEP 2

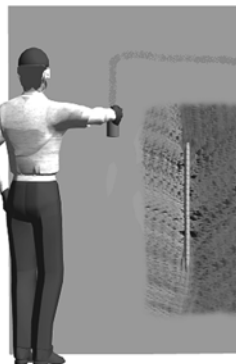

Mark perimeter of repair area. Layout should be simple geometric shapes.

pumps. All pumping equipment must have adequate controls to regulate flow rates and pressures.

What are the safety considerations?

Job site safety practices include, but are not limited to, the following where applicable:

- Material Safety Data Sheets (MSDS) available;
- Protective clothing worn by workers handling or exposed to hazardous materials;
- Use of protective eyewear during pumping and preparation;
- Availability of eye wash facilities; and
- Use of respirators during preparation.

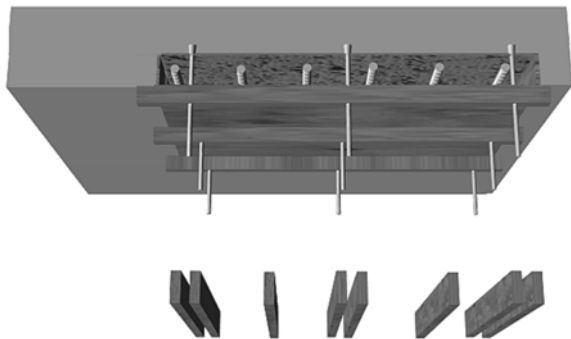

Erection of formwork with embedded anchors supporting formwork

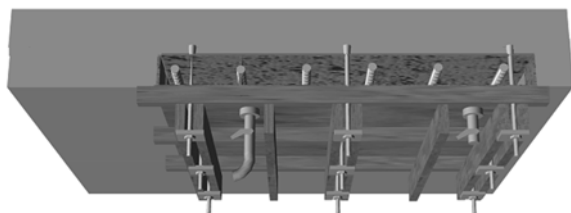

Formwork complete ready for pumpline hookup

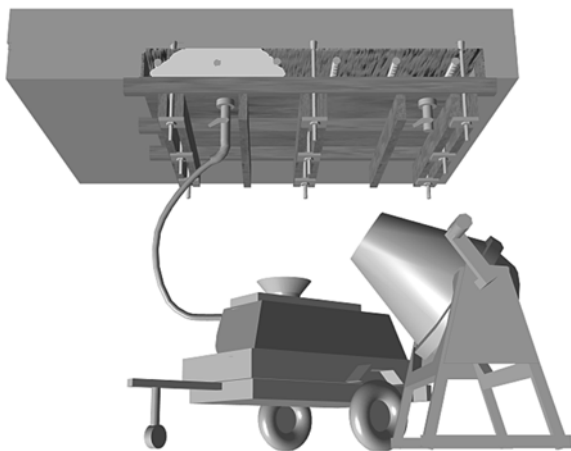

Pumpline hooked to form and pumping of repair material begins

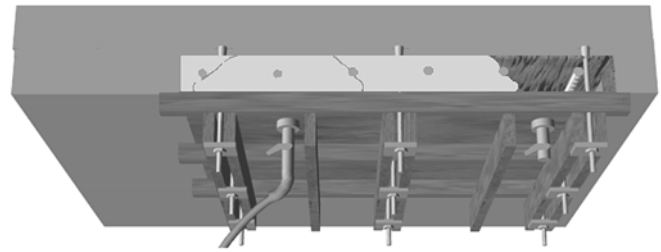

Pumping underway. Note flow path radiating from pump line port.

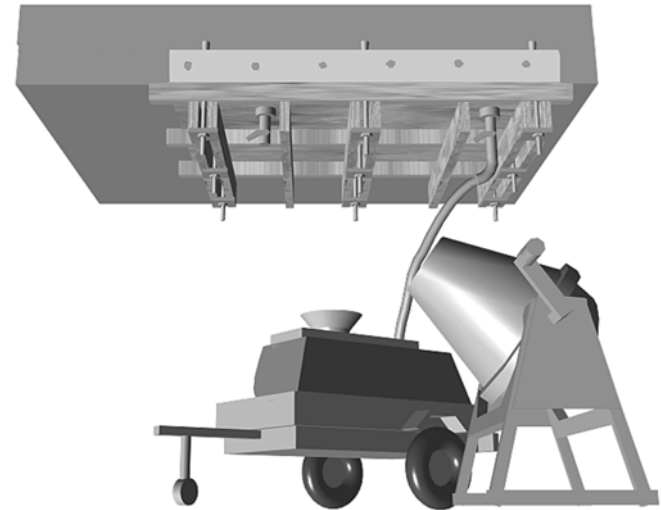

Cavity is filled and pressurized. Pump line is shut down.

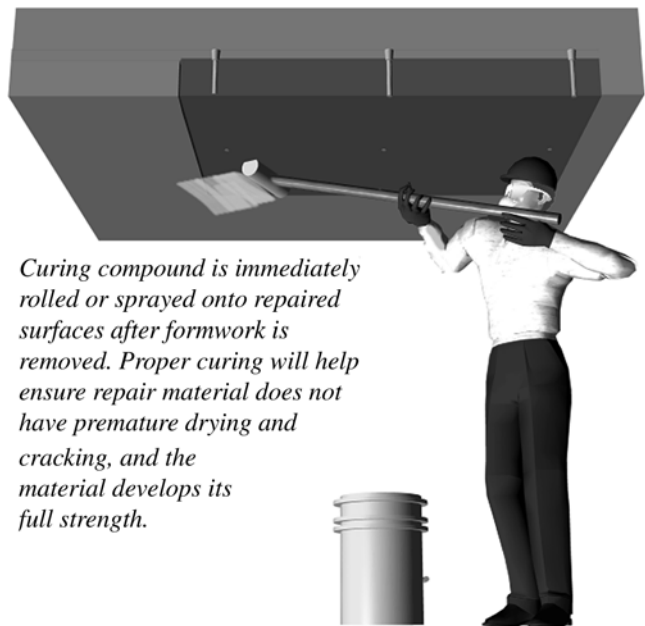

Curing compound is immediately rolled or sprayed onto repaired surfaces after formwork is removed. Proper curing will help ensure repair material does not have premature drying and cracking, and the material develops its full strength.

Fig. 2—Material placement: overhead application.

Types of Tensile Breaks

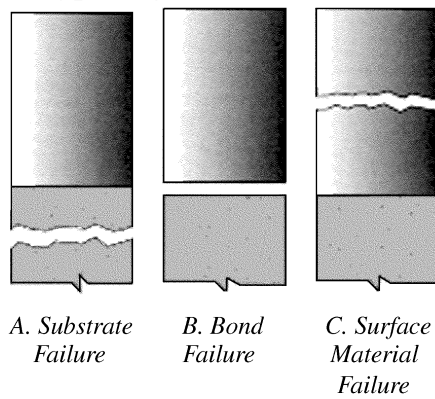

Device is glued to surface. Tension is applied.

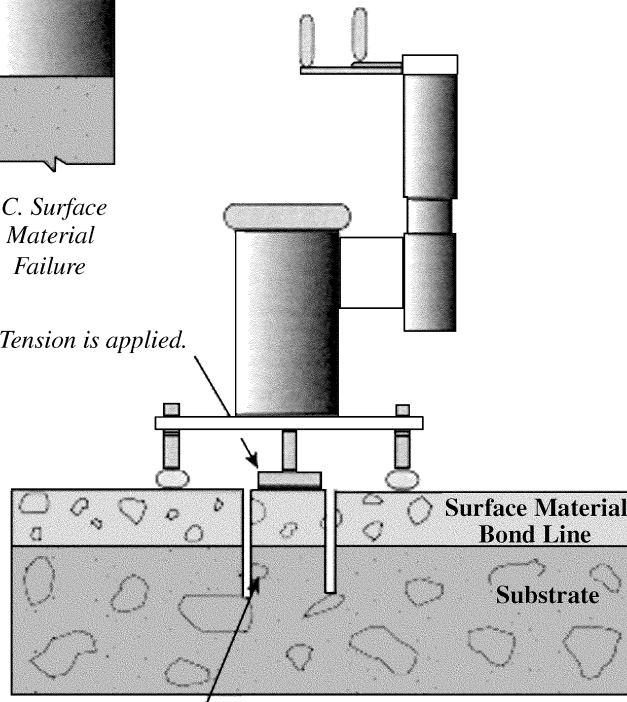

Cored hole through surface material and into substrate

Fig. 3—Test procedure.

It is the responsibility of the user of this document to establish health and safety practices appropriate to the specific circumstances involved with its use. ACI does not make any representations with regard to health and safety issues and the use of this document. The user must determine the applicability of all regulatory limitations before applying the document and must comply with all applicable laws and regulations, including but not limited to, United States Occupational Safety and Health Administration (OSHA) health and safety standards.

Preconstruction meeting and trial repair

Prior to proceeding with the repair, a preconstruction meeting is recommended. The meeting should include representatives from all participating parties (owner, engineer, contractor, materials manufacturer, etc.), and specifically address the parameters, means, methods, and materials necessary to achieve the repair objectives. Trial repairs using the proposed procedure and materials are highly recommended.

Repair procedure

Formwork construction—Formwork must accommodate the mass and pressure of the repair material. Design of the forms should follow standard practice for cast-in-place concrete construction except for the calculation of form pressure. Form pressure should be designed for a minimum of 14 psi (100 kPa). Maximum pressure exerted on formwork occurs after the formwork cavity is full and pressurized. Form-

work is best attached directly to the concrete surface with expansion anchors or standard form ties. All anchors should be preloaded to prevent slippage during placement. In some applications, shoring or scaffolding can be used to support the formwork. Forms should be constructed to fit tightly against existing concrete surfaces. Preformed foam gaskets or cast-in-place foam works well to address difficult-to-match surfaces. Attachment of the pump hose to formwork is achieved with various techniques, including the use of plumbing fittings with flanges and ball valves or the use of a pump-line attachment with hand-held friction fit-insertion followed by wooden plugs.

Pumping procedure—The sequence of material placement (see Fig. 2) into the formed cavity depends on the geometries involved. Vertical surfaces start at the lowest point, filling in a manner that prevents air entrapment. Arrangement of ports for pump line attachments is usually horizontal with spacing of 3 to 4 ft (900 to 1200 mm) in grid form. Pumping continues even after material flow occurs from adjacent ports to expel air. When the flow is without intrusion of air, the pump is temporarily shut off, the port closed off, and the pump line connected to the adjacent port that has seen flow. The sequence is continued until the cavity is filled. In some conditions, the cavity can be pumped from one port. In this situation, each adjacent port is capped off as flow occurs. It is necessary to monitor pump-line pressure to prevent excessive back-pressure when pumping long distances. Once the



Effects of not filling the cavity.

cavity is filled, the full-line pressure is available to pressurize the formed cavity.

Care must be exercised in the final pressurization because the excessive pump-line pressure (hydraulic pumps can exert in excess of 800 psi [5 MPa]) may cause the form to fail. In most applications, pressure gages should be attached to the pump line near the exit port to monitor cavity pressure. If the formwork fails due to overpressurization, the failure will generally occur as a slight movement in a form panel seam or perimeter seal. The failure is not explosive because there is no significant stored energy. Overhead placements are accomplished by starting at an extremity of the surface and proceeding in a fashion similar to vertical placements. Material will flow radially from the injection port to adjacent ports. Repairs involving soffit and vertical faces of members can be combined into one placement. In this case, placement begins at the lowest elevation and follows the procedure detailed above for each orientation. Large areas of repair should be sectionalized utilizing bulkheads. Bulkheads can be

constructed of repair material and left in place. Utilizing bulkheads and manageable placement volumes limits the risk of problems associated with large placements and allows pressurization to occur within shorter durations of material mixing.

How do I check the repairs?

After stripping of forms various tests can be performed to confirm the placement of repair material has achieved complete consolidation and intimate contact with the substrate to achieve bond. A uniaxial bond test can be performed by drilling through the repair into the substrate. A bonded plate attached to the core is pulled until rupture occurs. Bond values should exceed 100 psi (0.7 MPa), and in most cases exceed 150 psi (1 MPa). These tests are performed in accordance with ACI 503R Appendix (see Fig. 3).

The complete repair area should also be hammer-sounded or evaluated by other non-destructive methods to determine overall integrity. Any hollow sounds may represent poor bond or voids.

Sources for additional information

1. "Guide for Surface Preparation for the Repair of Deteriorated Concrete Resulting from Reinforced Steel Corrosion," No. 03730, International Concrete Repair Institute.
2. "Guide for Selecting and Specifying Concrete Repair Materials," No. 03733, International Concrete Repair Institute.
3. ACI Committee 347, "Guide to Formwork for Concrete (ACI 347-01)," American Concrete Institute, Farmington Hills, Mich., 32 pp.
4. ACI Committee 546, "Concrete Repair Guide (546R-96)," American Concrete Institute, Farmington Hills, Mich., 41 pp.
5. ACI Committee 503, "Use of Epoxy Compounds with Concrete (503R-93 (Reapproved 1998)), " American Concrete Institute, Farmington Hills, Mich., 1998, 28 pp.